













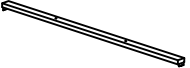

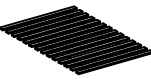

ASSEMBLY INSTRUCTIONS

MODEL : #1142-105 (V#12600CF SB1)

**NOTE : THIS ITEM NOT RECOMMENDED FOR COMMERCIAL USE
KEEP THIS DOCUMENT FOR REFERENCE IN CASE PARTS ARE NEEDED**

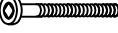
DO NOT TIGHTEN SCREWS UNTIL COMPLETELY ASSEMBLED !!

NO		DESCRIPTION	QTY
A		Headboard	1pc
B		Footboard	1pc
C		Side Rail	2pcs
D		Legs	4pcs
E		Center Rail	1pc
F		Support Leg	3pcs
G		Slat 14 Pcs	1pc

NO		DESCRIPTION	QTY
1		M4 x 65 mm	1pc
2		CSK M4 x 25 mm	4pcs
3		CSK M4 x 32mm	31pcs
4		JCBC M6 X 20	10pcs
5		JCBC M6 X 30	8pcs
6		JCBC M6 X 40	7pcs
7		Spring Washers	4pcs
8		Flat Washers	24pcs
9		Small Adjuster	3pcs

ASSEMBLY INSTRUCTIONS

MODEL : #1142-105 (V#12600CF5B1)

STEP 1 :

Install the legs (D) to footboard (B) and headboard (A).

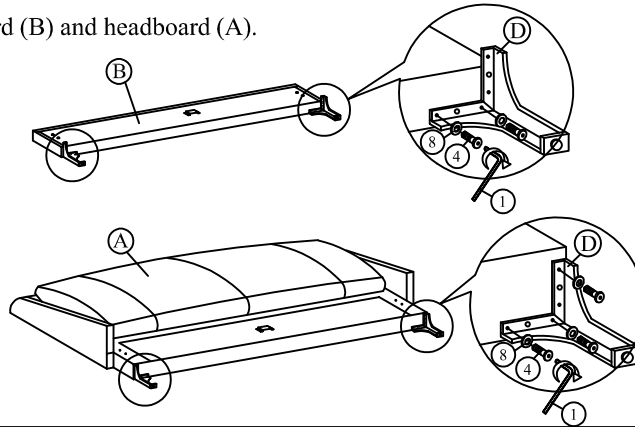

STEP 2 :

Attach side rail (C) to footboard (B) and headboard (A) by pushing the bracket down to fit it.

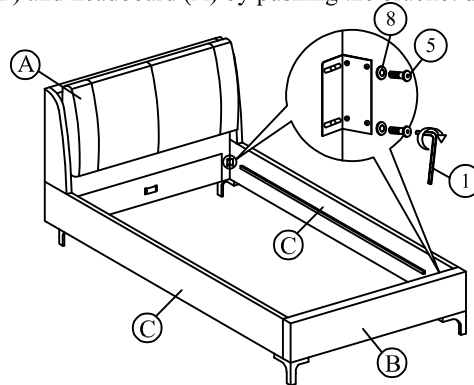

STEP 3 :

Tighten screws (3) and flat washer (8) using screwdriver (not included) to the footboard (B).

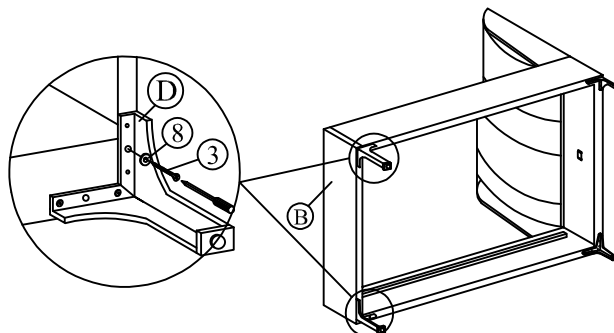

ASSEMBLY INSTRUCTIONS

MODEL : #1142-105 (V#12600CFSB1)

STEP 4 :

Attach the support legs (F) to the center rail (E) of the bed as shown.

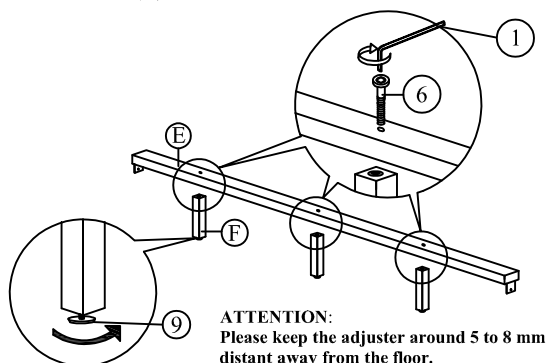

STEP 5 :

Slide the center rail (E) to the headboard (A) and footboard (B). Tighten screws (2) using screwdriver (not included) to the headboard (A) and footboard (B).

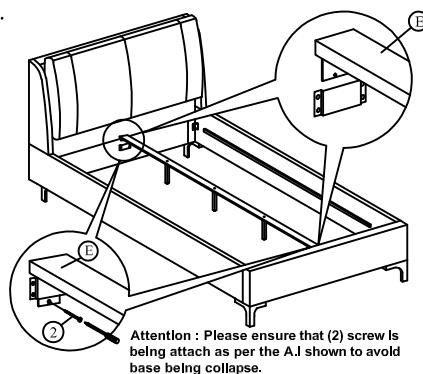

STEP 6 :

Affix the Slat (G) to the side rail support wood and the center rail (E). Tighten all the 4 corner.

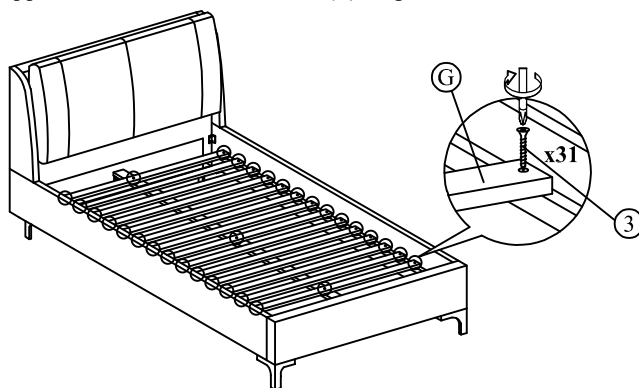

ASSEMBLY INSTRUCTIONS

MODEL : #1142-105 (V#12600CF SB1)

STEP 6 :

Tighten the headboard (A) back to side rail (C) to as shown.

